Digital I/O Board User Manual



An Abstract

This manual is for Digital I/o Board which enables to connect with external Digital devices and to appreciate original sound of digital using Sound Track 128 Gold, Sound Track 128 Ruby and Sound Track 97 PCI.

You can experience clearer and finer original sound than existing Analog I/O devices from CD-ROM Drive in your PC.

Using S/PDIF Digital system, you can change your PC into wonderful recording studio by connecting Digital I/O Board with DAT and external Midi sound sources.

To realize function described above, this manual explains how to install and use Digital I/O Board.

A Feature

Digital Input(CS8412)

- ✓ Monolithic CMOS Receiver
- ✓ Low-Jitter, On-chip Clock Recovery
- ✓ 256Fs Output Clock Provided
- ✓ Support : AES/EBU, IE958, S/PDIF & EIAJ CP-340
- ✓ Professional and Consumer Formats
- ✓ Extensive Error Reporting
- ✓ Repeat Last Sample on Error Option
- ✓ On-Chip RS422 Line Receiver

Digital Output(CS8402A)

- ✓ Monolithic Digital Audio Interface Transmitter
- ✓ Support : AES/EBU, IE958, S/PDIF & EIAJ CP-340
- ✓ Professional and Consumer Formats
- ✓ Host Mode and Stand Alone Modes
- ✓ Generates CRC Codes and Parity Bits
- ✓ On-Chip RS422 Line Driver
- ✓ Transparent Mode Allows Direct Connection of CS8402A and CS8412 or CS8401A and CS8411A

Shape of Digital I/O Board

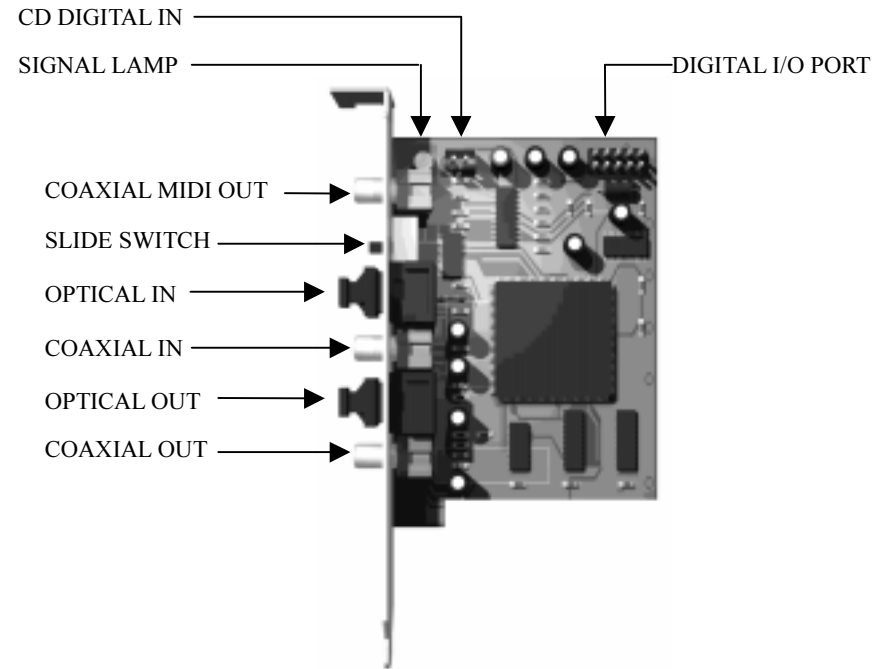

• CD Digital In

Connect with Digital Out in CD-ROM Driver to CD Digital Audio In.

• Signal Lamp

Red Lamp will be lit when Digital I/O Board detects Digital signal. With this Lamp, you can ascertain whether or not Digital I/O Board works.

• Coaxial MIDI Out

Connected to Digital In of MIDI device, it will generate Digital signal into external MIDI Device.

• Slide Switch

CD: Use when selecting internal CD-ROM Driver

DIGI: Use when receiving external Digital input.

• Optical IN

Connected to Optical Out of instruments, it will receive sound of instruments in Optical.

Note : It can't be adopted by model.

- **Coaxial IN**

Receive sound of instruments in Digital signal. Connect with Digital connector of your digital device.

- **Optical Digital Out**

Connected to Optical Out, it will generate sound of sound card in optical.

Note : It' can't be adopted by model

- **Coaxial Digital OUT**

Connected to Digital In of instruments, it will generate sound of sound card in Digital

- **Digital I/O Port**

Connected to sound card, it will generate sound of sound card into Digital I/O Board.

Installation of Digital I/O Board

1. Open the PC case, mount Digital I/O Board into empty I/O Board.
2. Either 10-pin flat cable or round thick cable is provided. Connect 10pin-flat or thick cable with 10pin port of Sound Track family. In 10pin-flat cable case, make sure that red-line of 10pin- flat cable is located in same direction with small triangle marked on Sound Track family. In round thick cable case, make sure that thin black line of thick cable is located in same direction with small triangle marked on Sound Track family.

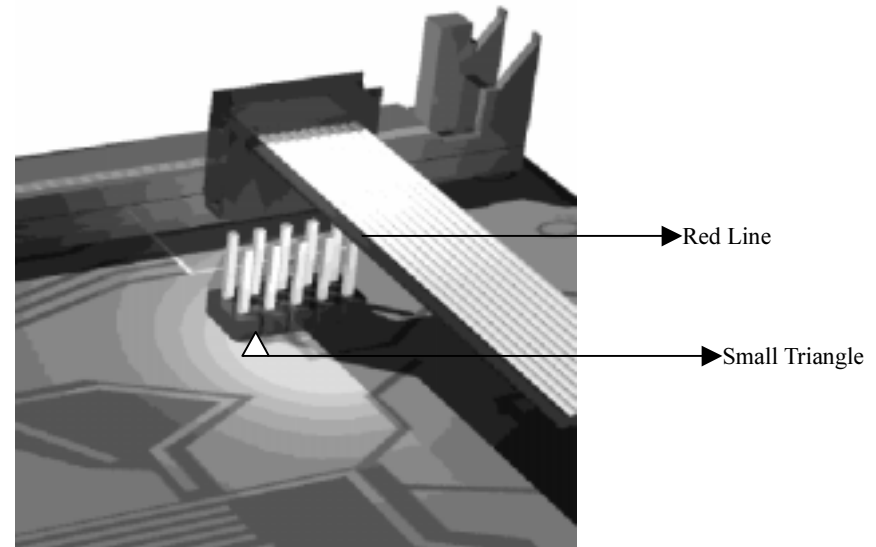

Notice: Digital I/O Board won't work if red-line of 10pin-flat cable is in opposite side..

3. Connect 10pin-flat or round thick cable with 10pin port of Digital I/O Board. Make sure that red-line(thin black line) of 10pin-flat(thick) cable is located in same direction with CON1 marked on Digital I/O Board.

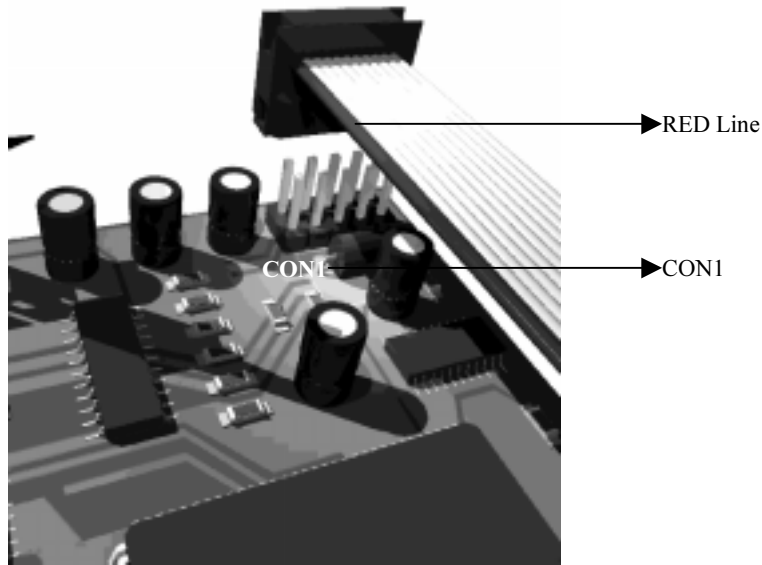

Notice: Digital I/O Board won't work if red-line of 10pin-flat cable is in opposite side.

4. Connect black side of 2pin cable to Digital Audio Port on CD-ROM Drive. 2pin cable is divided by White and Black. Make sure that Black is connected with G(Ground) and White is D(Digital Out) on CD-ROM.

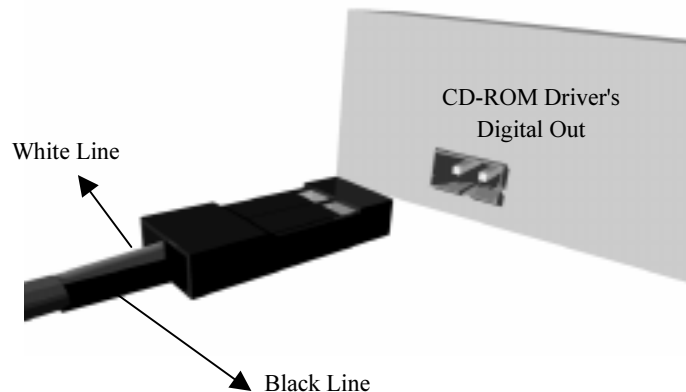

Notice: Digital I/O Board won't work if cable is in opposite side.

5. Connect the other side of 2pin cable to White port(CD Digital IN) on upper side of Digital I/O Board.

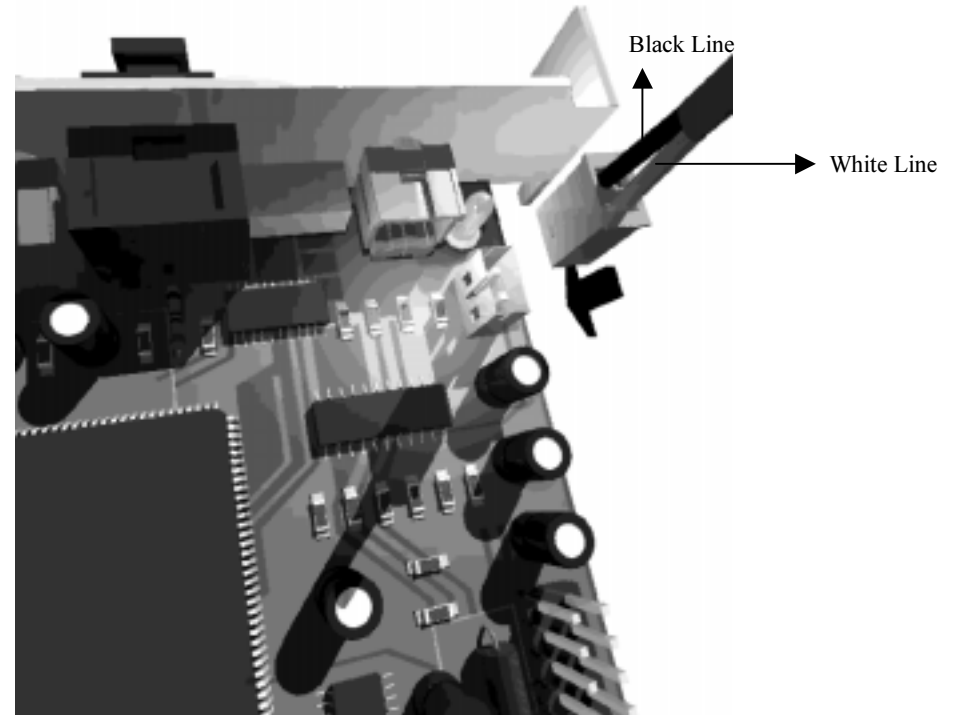

6. Cover the PC with case and screw up.
7. Connect to external Digital device. You can remove the cover of Optical In. Grip quad angle of Optical In and pull it out. Skip this if there's no external Digital device.

Notice: Don't connect to Coaxial In and Optical In simultaneously. RCA port and Optical can be connected simultaneously when using Digital output.

8. Settle slide switch which is on the rear of Digital I/O Board. Select CD when using Digital Audio in internal CD-ROM or DIGI when using external device.
9. Turn on the PC after checking Installation.

Software setup

1. Basic I/O path of Sound Track 97 PCI as follows;

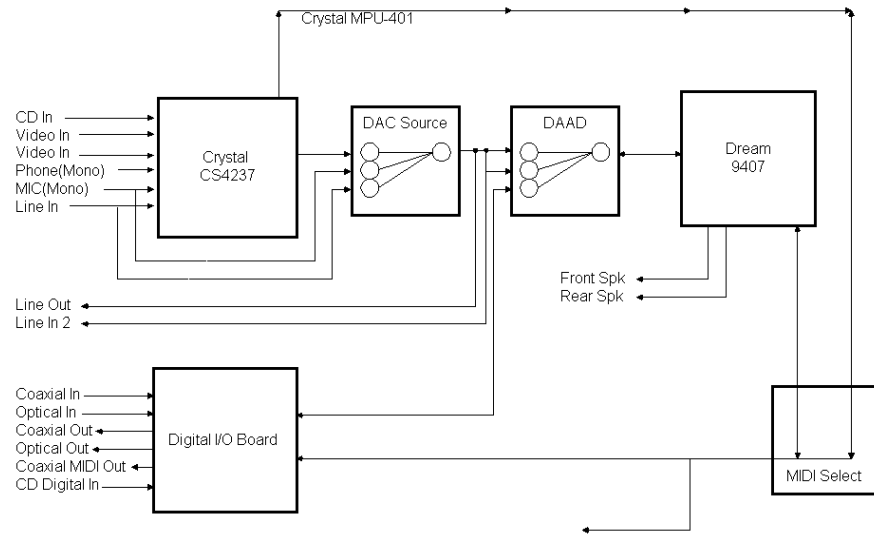

2. If you want to use S/PDIF I/O of Digital I/O Board, run INPUT SELETOR program in folder of Sound Track Series after booting Win 95.
3. Start Button → Program → Sound Track Series → INPUT SELETOR

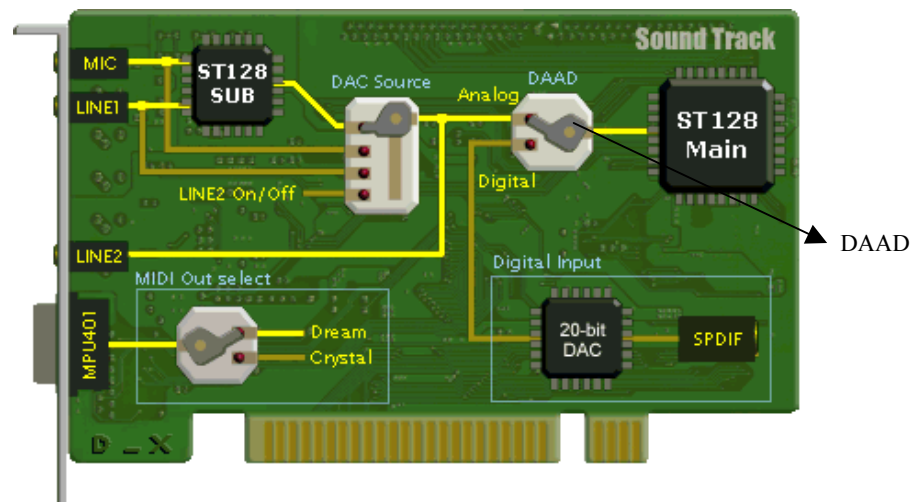

4. Refer to the following figure and change DAAD Item into Digital in INPUT SELETOR.
5. Run CD-ROM or external Digital device. There's a CD-ROM drive that can't support Digital Out. Also some CD-ROM drive make noise even it support Digital Audio Out. But Digital I/O Board has no relation with it.
6. All kinds of Digital signal of sound will be generated by RCA port and Optical Output of Digital I/O Board.

How to appreciate CD Digital Audio

1. Insert Audio CD to CD-ROM Drive
2. Adjust Slide switch of Digital I/O board to CD
3. Start Button → Program → Sound Track Series → Input Selector
4. Refer to the previous figure and change DAAD item in to Digital in INPUT SELETOR
5. Play Audio CD.